

An Accurate Grinder for your lathe

By C.W. Woodson

From the pages of Model Craftsman magazine June, 1937

As shown in Fig. 1, the tool post grinder for which plans are given here can be used to finish up delicate work to more accurate dimensions than can be done with a lathe tool. For such operations as lapping cylinders, facing surface plates, and other work, nothing can take the place of a grinder. A ¼ h.p. motor should be used, as this amount of power is necessary to make good cuts.

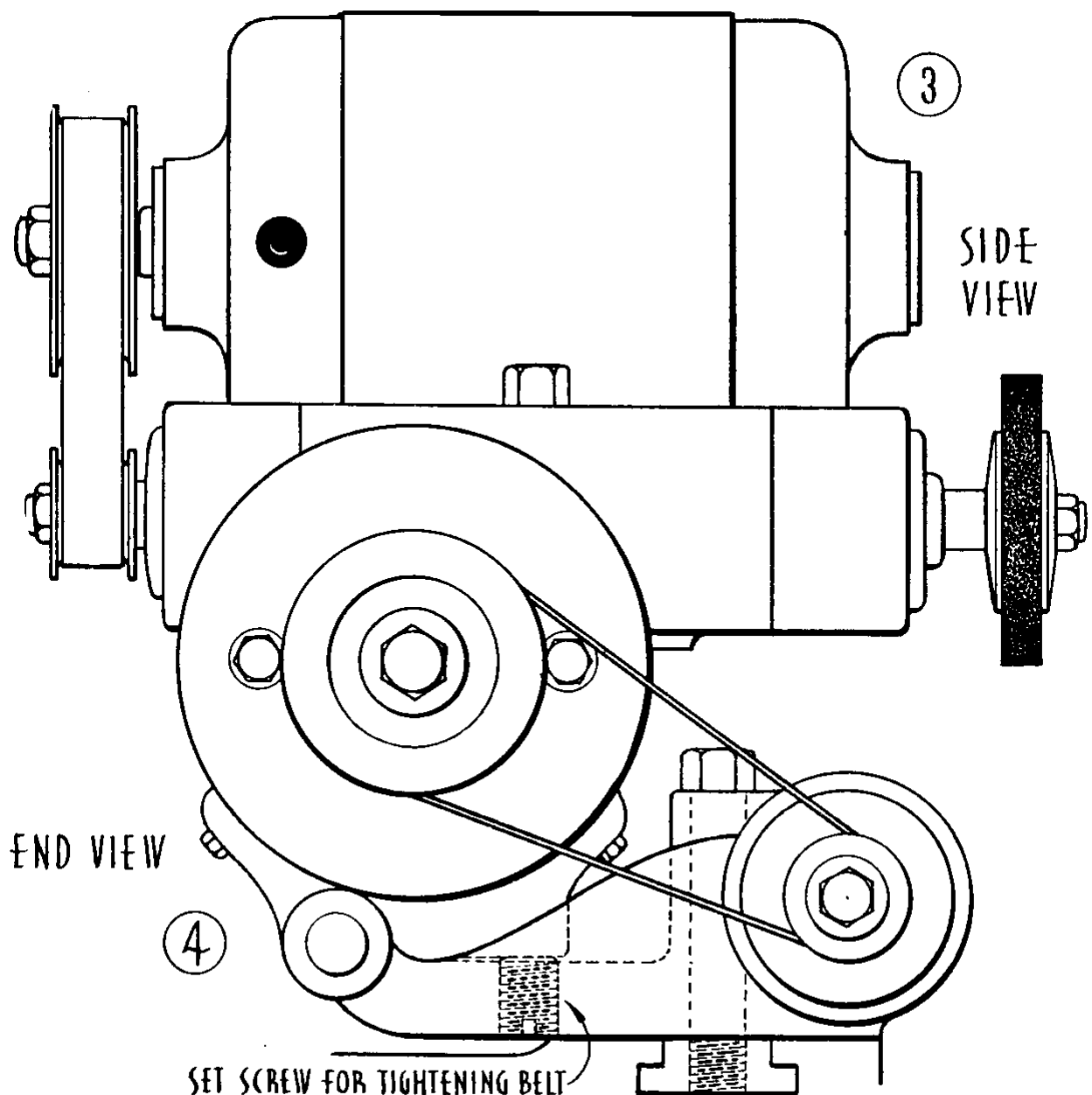

Ball bearing, mountable directly on the slide rest of the lathe, this very good grinder will enable you to turn out fine surfaces.

As can be seen from the drawing in Fig. 2, the elements are very simple. There is a casting (see Fig. 7) which attaches to the shoulder piece, shown in Fig. 13. Attached to this casting (as may be seen in Fig. 4) is a rocker cradle, Fig. 8, which may be a casting, or built up of plate.

DETAILS ON GRINDER OF EXCELLENT DESIGN

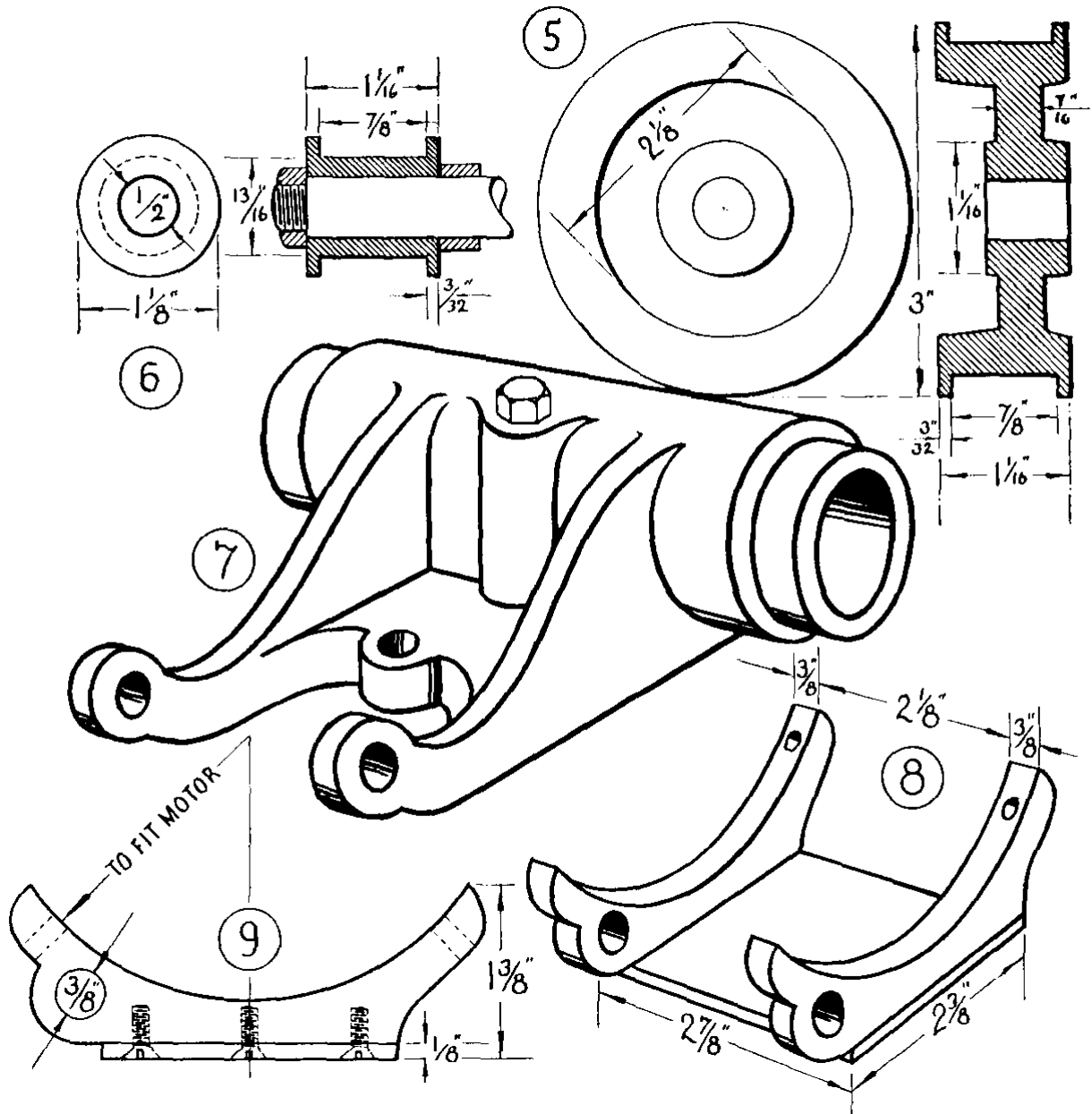

The live spindle, shown in Fig. 12, is a simple piece of hardened cold rolled steel, $\frac{3}{4}$ " in diameter and mounted in ball bearings by simple retainers.

The belt adjustment is taken up by the screw, shown in Fig. 4. The idea of a V-belt drive may at once suggest itself, but I strongly advise the use of a woven flat belt because of the speed involved. V-belts at high speeds use considerable power. The grinding wheels may be obtained in standard sizes from any local abrasive store, or your hardware dealer will be able to get them by mail order.

To construct the grinder proceed as follows: Make a pattern for the piece shown in Fig. 10. The 1 1/8" hollow portion should be cored out. Have this poured in iron and then drill the stud holes. Turn the 1/2" shoulders on each end down to outer thread size at which point the job will look as shown in Fig. 7. Make bronze retainer caps for the shoulder ends. These caps are shown in Fig. 14, and their application to the castings is shown in Fig. 12. The bearings can be purchased from any automotive supply for around 75 cents apiece. The socket size for the bearing can be worked out on the lathe by taking light cuts until the bearing is a sliding fit in the socket. Do not drive fit this, because any heat will affect the accuracy of the outer ring, and make the grinder run out of true.

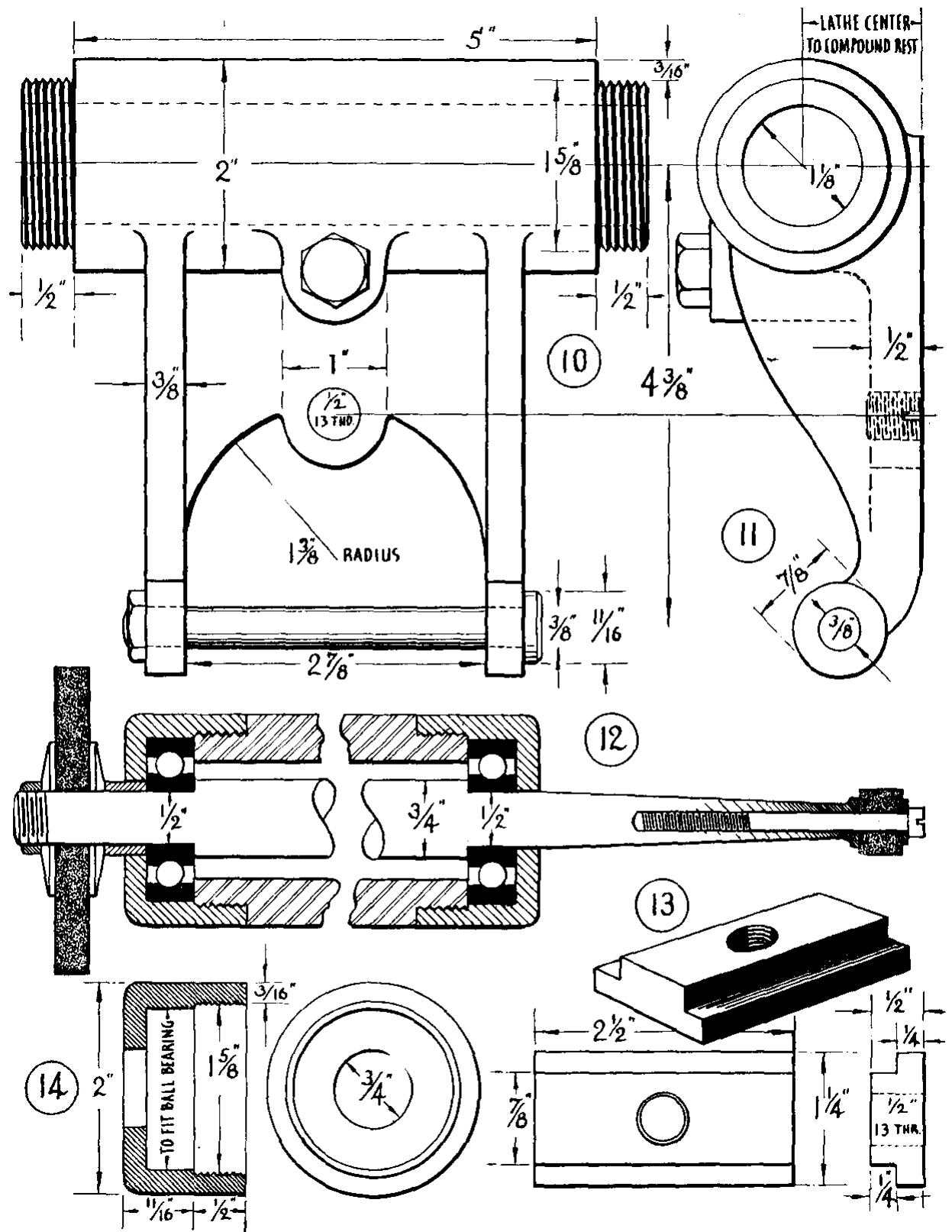

Flat belting is used for high speed work. Only one casting needed.

The 3/8" end plates of the motor carriage are shown in Figs. 8 and 9, are bored so that screws can be tapped into the motor housing. The slide rest gib, shown in Fig. 13, will fit the slide rest of a popular 9" lathe.

The pulley diameters, shown in Figs. 5 and 6, will give the proper spindle speed with a motor turning 1750 r.p.m.

A hex head nickle steel bolt will have to be provided in the proper length for the gib and carriage casting.

See to it that the thread on the driving pulley end of the spindle is in opposite rotation to the rotation of the motor.

The up and down adjustment to allow centering height for the axis of the grinder can be taken care of by shimming between the casting and the gib with washers. As shown, the casting height brings the axes coincident. The driven pulley on the spindle is made tight by the nut on the end of the shaft. This pulls the pulley up against the collar, which in turn rests against the inside ring of the bearing. In fastening the pulley do not tighten it too hard--slight pressure is sufficient.

You will note that a large wheel and a small wheel are shown in Fig. 12. To drive the large wheel a variation of the pulley in Fig. 6 can be applied to the long end using a taper collar pulley with a taper sufficiently large to bring the pulley in line with the motor pulley. The taper of this will be sufficient to give tight fit.

The compound fit on the slide rest will allow a number of operations to be performed; such as grinding cylinders, valve faces, dead center spindles, check valves, and the like. Constructed as shown, this post grinder can be built for less than 15 dollars and will make a valuable adjunct for engine builders, who require accuracy in fitted surfaces.

