

Drive Your HACKSAW *Electrically*

ANY ordinary hack-saw frame with the handle removed can be fitted to this simple drive unit, making an efficient power hack saw that will handle all kinds of light and medium work.

Fig. 1 shows side and end views of the table and gives you a general idea of the assembly. You don't have to be particular about the dimensions of the table. The main thing is rigidity and sufficient weight to absorb vibration of the reciprocating parts. A 1/4-hp. motor supplies the power through two sets of reducing pulleys, which brings the speed of the saw down to about 90 strokes per minute. The length of 3/4-in. shafting which

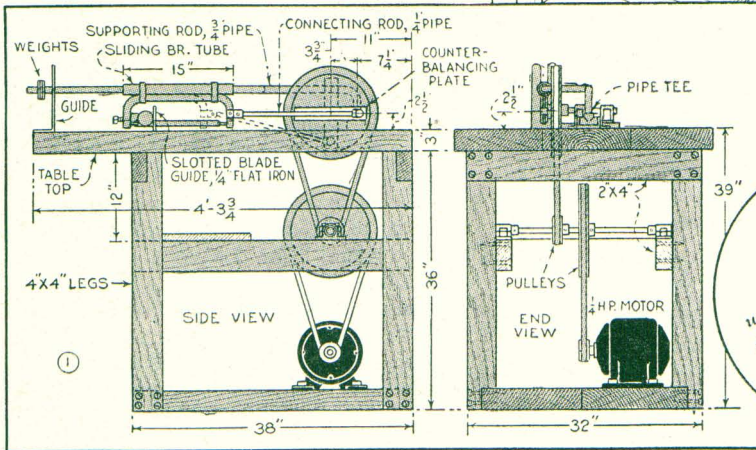
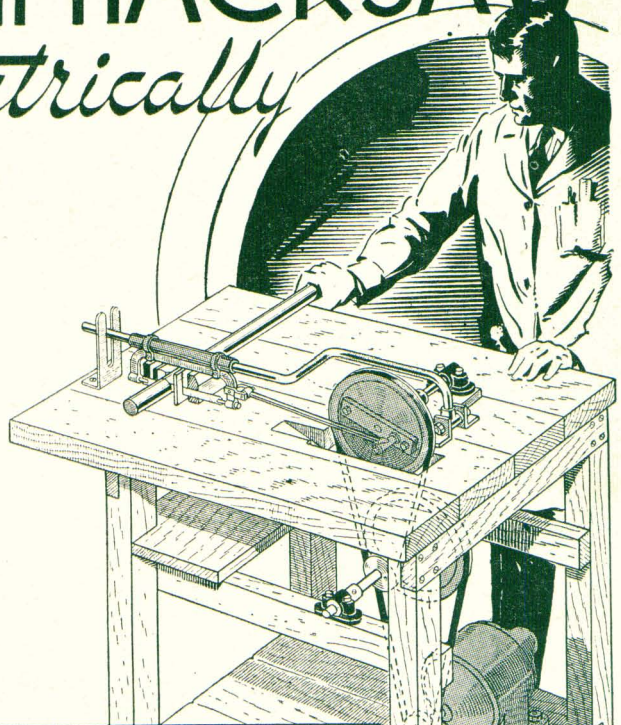

Any ordinary hand hacksaw can be used with this simple power drive. The saw frame is clamped to support arm, which is weighted

Rubber Heels Cushion Motor

To reduce vibration of electric motors to a minimum, shock-absorbing motor mounts for floating-type rails can be made from a pair of rubber heels. Cut a metal plate to fit the recess in the top of the heel and drill two holes through

the heel and plate to line up with rail clips. Countersink the flat-head bolts in the plate and bolt the three together. Fasten the heels to the bench with three screws or bolts, using washers under the heads.

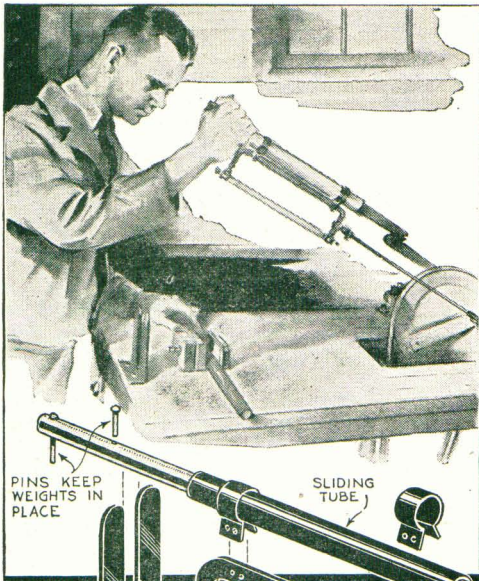

PINS KEEP WEIGHTS IN PLACE

SLIDING TUBE

The support arm is hinged so that the saw may be raised easily

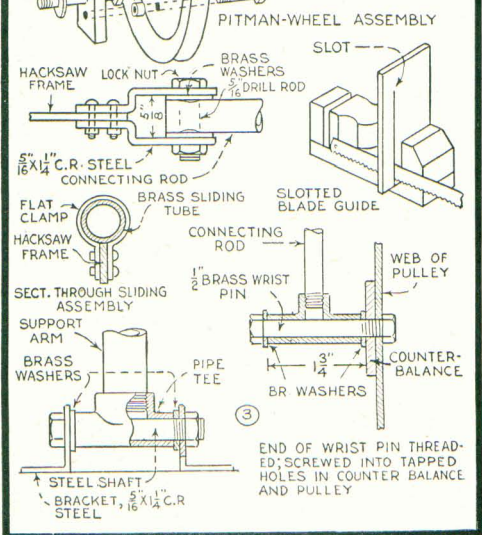
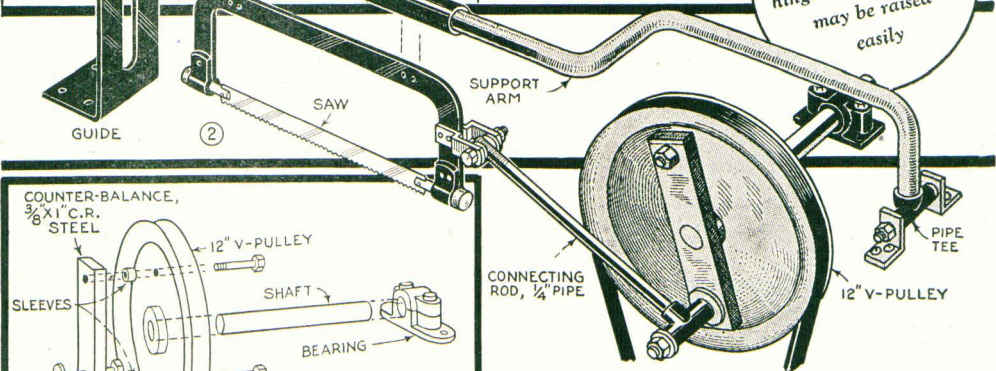

supports the intermediate and top pulleys turns in sets of $\frac{3}{4}$ -in. babbitted split bearings. Note that setscrew collars are used on each shaft. One face of the top or driving pulley is fitted with a counterbalancing steel plate as in Figs. 2 and 3. The counterbalance is bolted to the pulley. Construction of the crankpin is shown in Fig. 3, the lower right detail. A section of $\frac{1}{2}$ -in. brass rod is threaded on both ends and screwed into a tapped hole in one end of the counterbalance and through the pulley. This crankpin is secured with a nut at the back of the pulley. A $\frac{1}{4}$ -in. pipe tee which has been reamed to fit

serves as a driver for the connecting rod which is made from a length of $\frac{1}{4}$ -in. standard pipe. The forward end of the connecting rod is drilled for a $\frac{5}{16}$ -in. steel wrist pin threaded at both ends for lock nuts. The assembly is made as in Fig. 3. To guide the hack saw in a straight path, it is necessary to make a supporting arm either of $\frac{3}{4}$ -in. inside diameter iron pipe or brass tubing of the same size. Figs. 2 and 3 show the method of fastening this arm to the table. A $\frac{1}{4}$ by $\frac{1}{4}$ by $\frac{3}{4}$ -in. pipe tee is used as the moving part of the bearing. The tee is reamed out to fit over a $\frac{1}{2}$ -in. steel shaft. It is necessary to make an S-shaped bend in the arm as in Figs. 2 and 3. The best way of making the bend is to fill the $\frac{3}{4}$ -in. pipe with sand and place caps on each end, heat to a dull red and bend carefully in a vise. Brass tubing

can be bent cold. The surface of the pipe which supports the hack-saw guide should be polished smooth. The slide is a length of brass tubing which will telescope over the polished section of the supporting arm. The hack-saw frame is fastened to the guide with the aid of clamps as in Fig. 2. These can be riveted to the saw frame or held with small bolts.

The pressure applied to the blade when cutting is regulated by weights on the outer end of the supporting arm as shown in Fig. 1. These weights can be made by drilling a hole in cold-rolled steel plate of such a size that the piece will slip easily over the pipe. Setscrews or pins can be

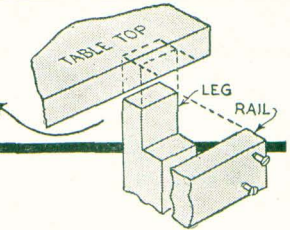
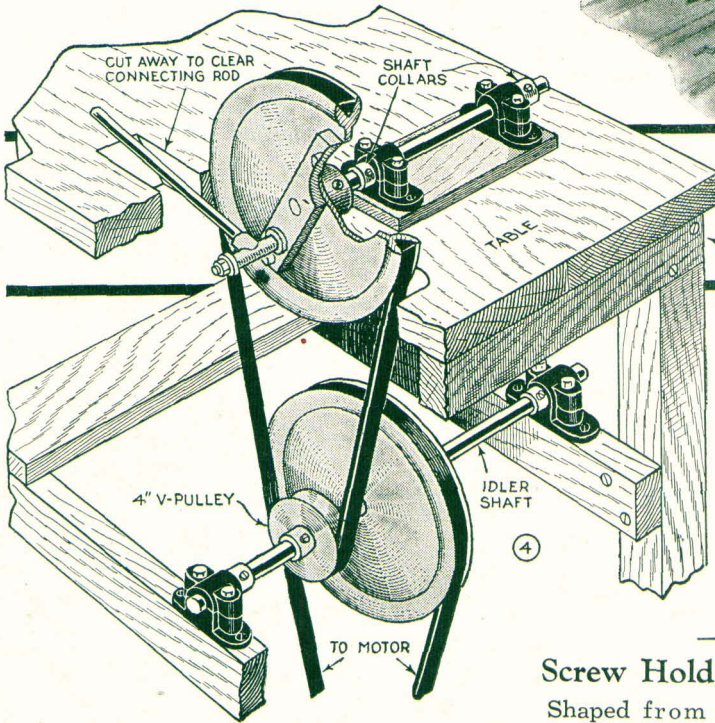

the vise guides the saw blade. The guide plate is fastened to one vise jaw with machine screws. Fig. 4 shows the assembly of the speed-reducing drive. All pulleys are of the V-type for $\frac{1}{2}$ -in. belt.

used to hold the weights in place. Different materials require slight variations in blade pressure for the best cutting action. The support-arm guide, Fig. 3, can be made from $\frac{1}{4}$ -in. flat iron, the slot being of the same width as the diameter of the pipe. If necessary, the guide should be blocked up on the bench, so that the arm will reach the bottom of the slot just as the saw breaks through the work.

A standard toolmakers' vise can be used to hold the work. A slotted plate fitted in

Screw Holder for Screwdriver

Shaped from a piece of thin spring steel, this attachment will enable you to start screws in places where it is impossible to reach with the hands. A slot with a hole at one end permits a screw head to be inserted and held true for starting it straight.

