

Rauchmelder

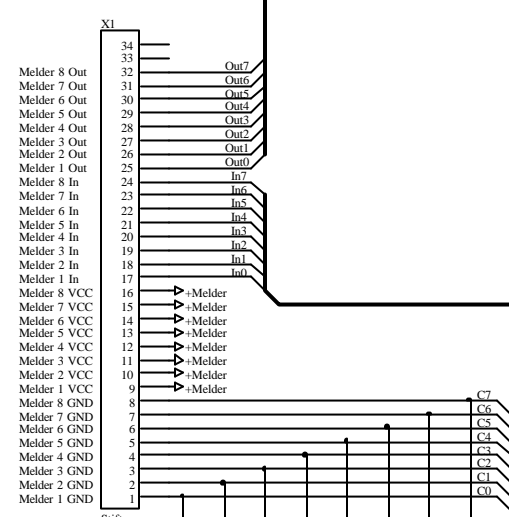

Melderschlüsse

1 : GND (Schwarz)
 2 : Alarmmeldung (Rot)
 3 : Alarmgeber (Gelb)
 4 : +Versorgung (Weiss)

Jeder Rauchmelder wird über einen Kippschalter mit +Melder verbunden!

Referenz für Stromerkennung

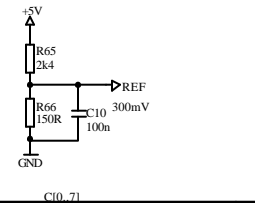

Komparatoren

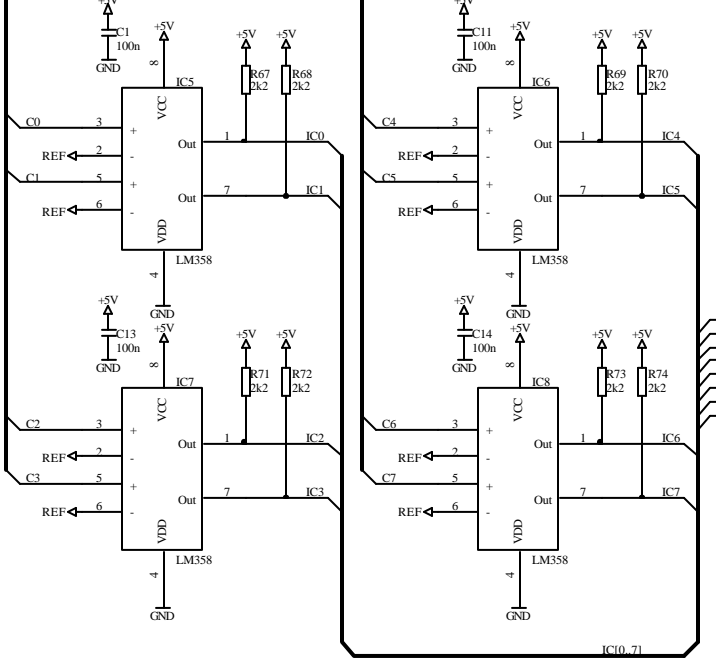

Stromerkennung

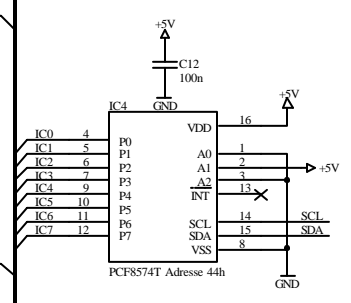

+Melder von den Schaltern

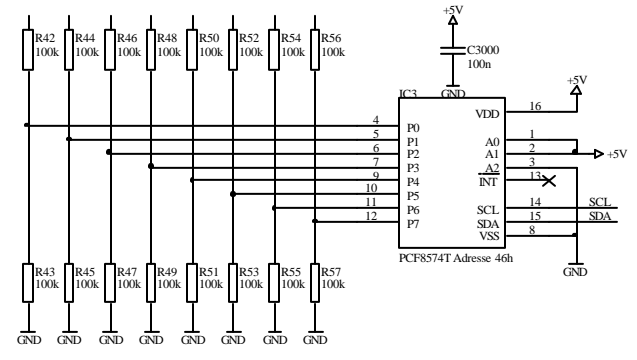

Schalterstatus

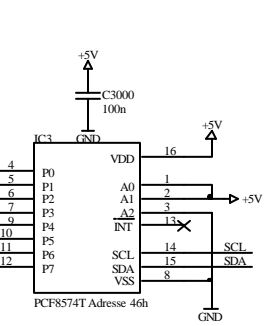

Systemschnittstelle

